

Vacuum valve (spring loaded)

12501, 12525, 12537, 12515

Vacuum valves are used in the food or drink, pharmaceutical and chemical industries. They are used for protection against a negative pressure in tanks and other enclosed systems.

Valve types spring-loaded, are characterized by:

	12501	12525	12537
Valve cone	plastic or stainless steel*	stainless steel	stainless steel
Housing shape	centric	centric	eccentric
Mounting position	vertical, horizontal	vertical, horizontal	horizontal
Connection	DIN 11851	DIN 11851	DIN 11851
Nominal sizes	DN 25/40 32/50 40/50 50/65	DN 25/40 32/50 40/50 50/65	DN 50/65 65/80 80/100
	* DN 65/80 80/100	entfernt	
Equipment	heating cartridges		
	12515		
Valve cone	stainless steel		
Housing shape	centric		
Mounting position	vertical		
Connection	welding flange		
Nominal sizes	DN 100 125		
Equipment	pneumatic lifting, heating cartridges		

Note: Pneumatic lifting

During CIP cleaning lifting only when the tank is unpressurized (pressure < 0.1 bar).

Product range

Materials	stainless steel 1.4404
Gaskets	EPDM, FDA proof
Surface	≤ 0.8 µm

Other parts

Materials	stainless steel 1.4307
Surface	precision turned

Production

Fluids (nontoxic)	Fluids/gases/steam (Group II, PED 2014/68/EU)
Set pressure	3 – 5 mbar
Temperature	0 - 80 °C / plastic cone 0 - 140 °C / stainless steel cone
Pressure aera	6 bar-g / plastic cone 10 bar-g / stainless steel cone

Vacuum valve (spring loaded)

12501, 12525, 12537, 12515

Valve types

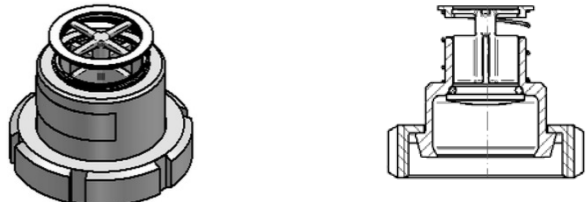
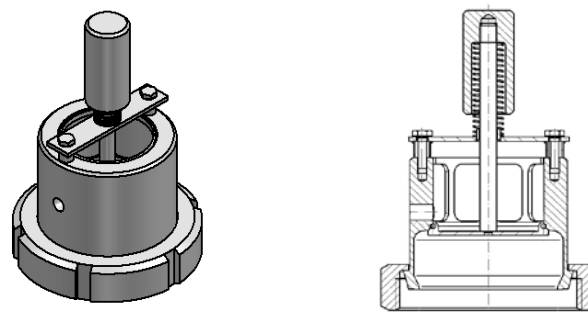
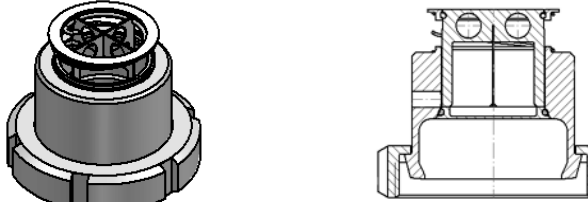
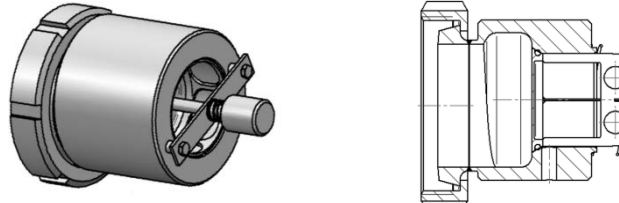
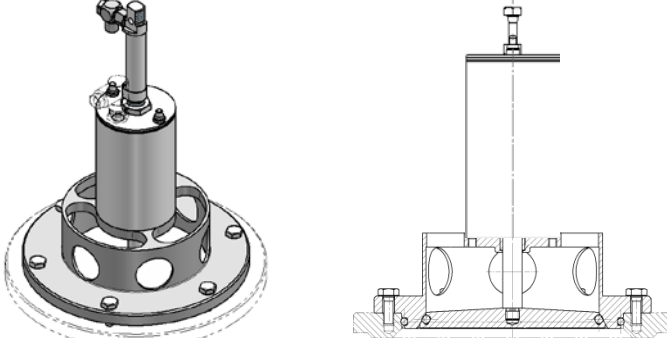
12501		DN 25 - 50 Height ↑ 60 - 85 mm
		DN 65, 80 Height ↑ 105, 230 mm
12525		DN 25 - 50 Height ↑ 60 - 85 mm
12537		DN 50, 65, 80 Length → 105, 130, 140 mm
12515		DN 100, 125 Height ↑ 200 mm ↑ 280 mm with pneumatic welding flange \varnothing 230 mm Version with pneumatic lifting (Equipment)

Vacuum valve (spring loaded)

12501, 12525, 12537, 12515

Flow capacity

Type 12501, 12525, 12537

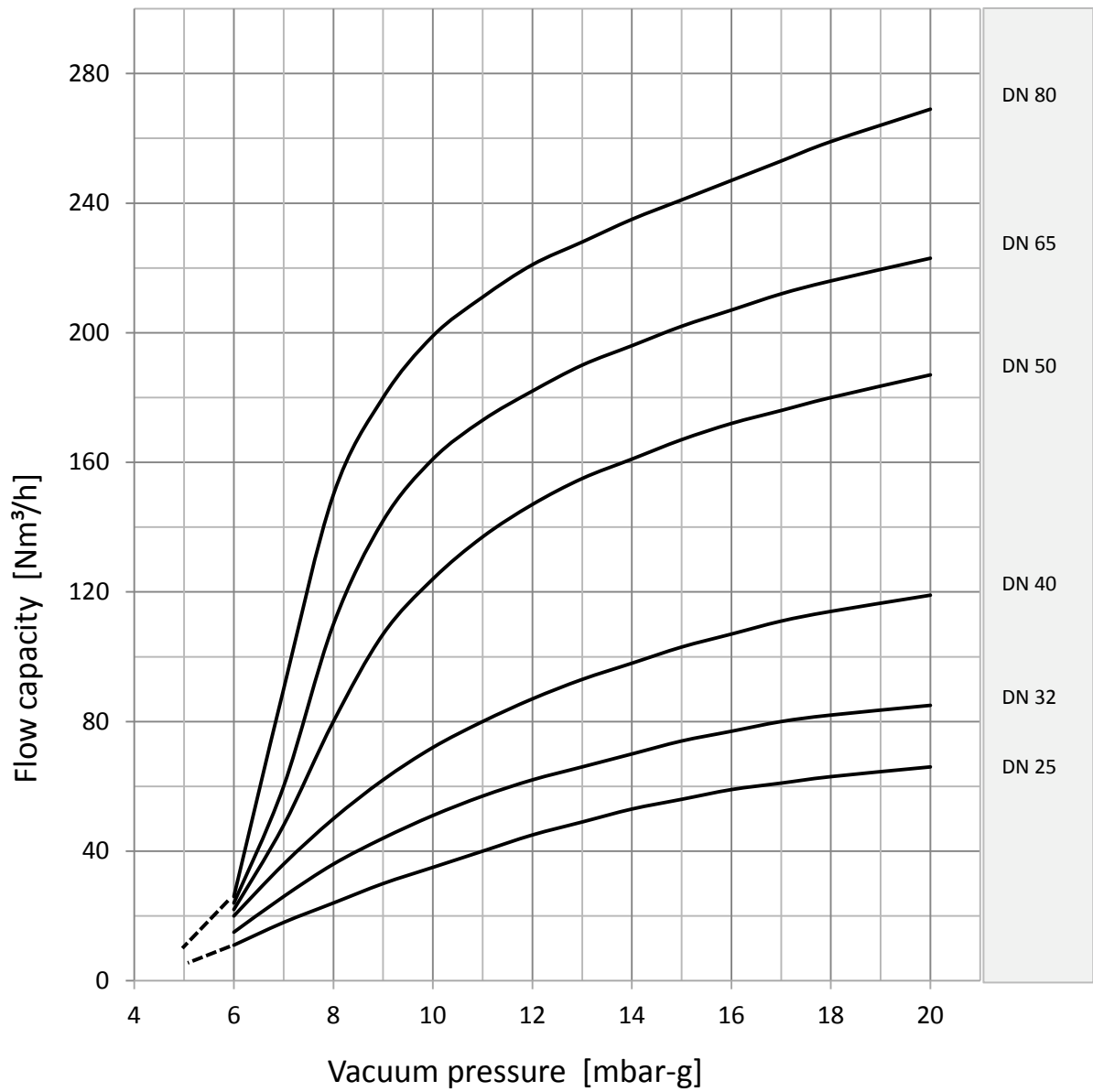

Vacuum valve (spring loaded)

12501, 12525, 12537, 12515

Type 12515

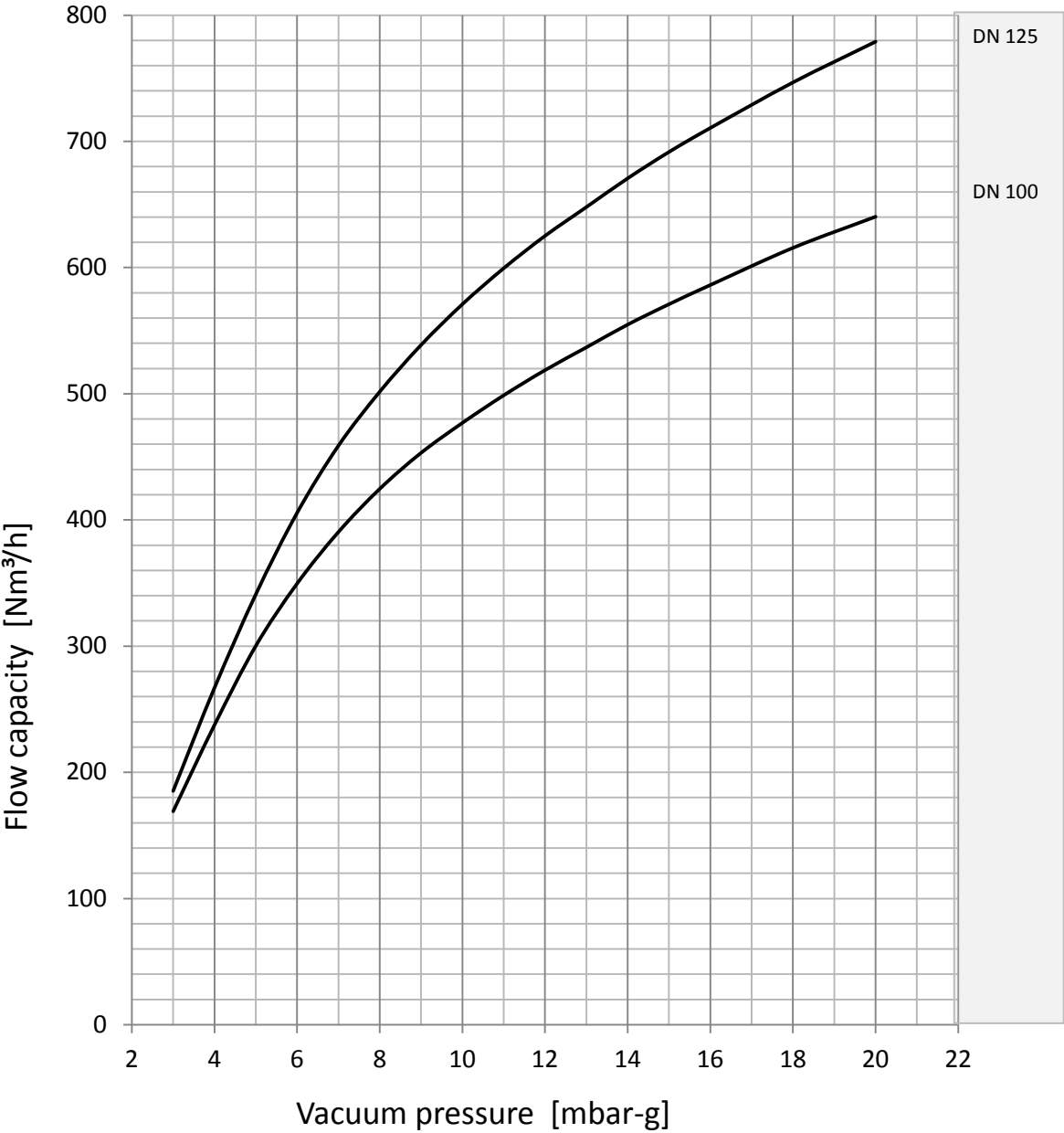

Conversion: 1 mbar ⇔ 10 mmWC ⇔ 100 Pa ⇔ 0.1 KPa