

## Safety relief valve, spring-loaded

### 32500/32501/32502

#### Description

Safety relief valves are used in the beverage and food processing industries, as well as in the chemical-pharmaceutical industry.

Safety relief valves:

- protection of pressurized systems against overpressure
- subject to the Pressure Equipment Directive 2014/68/EU
- may be used for the intensified purpose only
- fulfil the requirements of AD 2000/ A2 and DIN EN ISO 4126-1

#### Valve types

Type	Fluids	Lifting manual	Seals EPDM / FKM	Connection variants
32500	G/D	X	X	thread
32501	G/D	X	X	K/M 11851
32502	G/D	X	X	K/M 11851, housing with mounting flange for bunging glasses

Air/Gases (G), Steam (D)

#### Valve data

Type	Safety valve
Type of functioning	Opens with pressure/closes with spring force
Order code	325xx/326xx

#### Product range

Materials	Stainless steel 1.4404
Seals	EPDM, optionally FKM/FPM (all FDA proof)
Surface	≤ 0.8 µm

#### Other parts

Materials	Stainless steel 1.4301, 1.4307
Seals	EPDM
Surface	Precision-turned, matte

#### Production / CIP

Applications	Free outflow
Fluids (nontoxic)	Fluids/gases/vapours (Group II, PED 2014/68/EU) Readily commercially-available CIP cleaning media with 2-4 % lye/acid
Performance data	Performance data within 10 % pressure increase
Operating pressure	PS min/max 0/10 bar-g
Temperature	TS min/max -20/160 °C
Control air pressure	5 – 7 bar, compressed air connection Ø 6/4 mm

CE 0062



## Safety relief valve, spring-loaded

### 32500/32501/32502

#### Valve construction

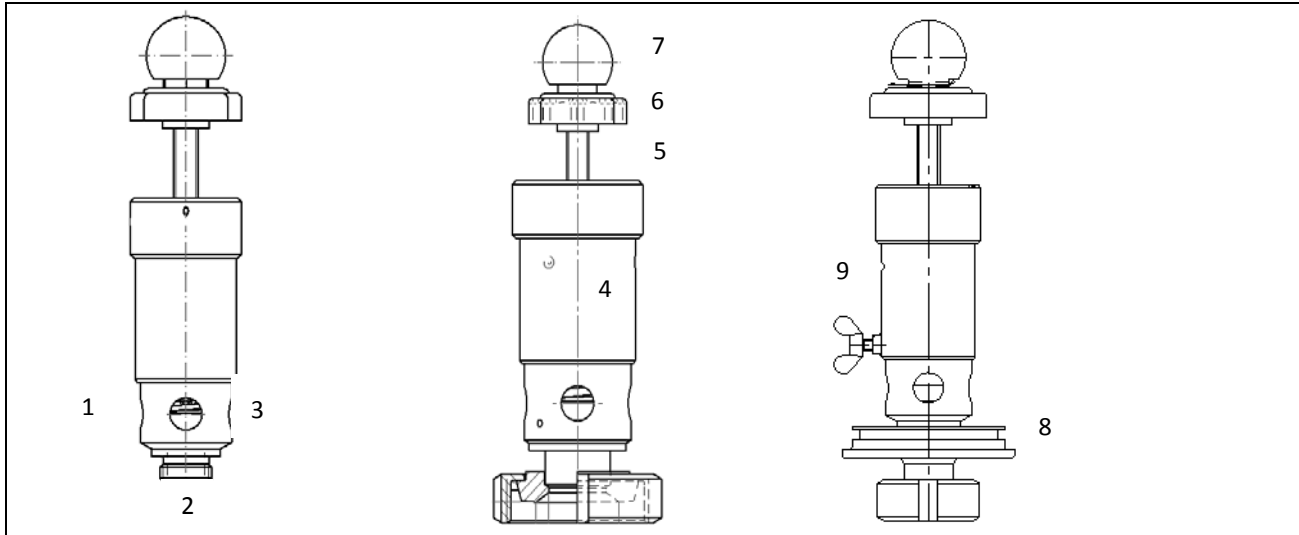

Fig. 1: Type 32500

32501

32502

- |   |                                  |   |                 |
|---|----------------------------------|---|-----------------|
| 1 | valve housing                    | 5 | valve rod       |
| 2 | valve inlet [E] – supply pipe    | 6 | star grip       |
| 3 | valve outlet [A] (blow-off hole) | 7 | ball knob       |
| 4 | upper valve body                 | 8 | mounting flange |
|   |                                  | 9 | adjustment      |

#### Dimensions

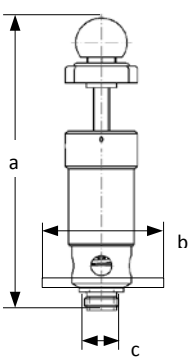
AH-SV-32500/32501/32502	DN [E]	a [mm]	b [mm]	c [connection]	pressure [bar]	weight [kg]
	<b>32500</b>					
	15	185	---	G ½"	0,5 - 5,0	0,5
	25	185	---	G 1"	0,5 - 4,0	0,8
	<b>32501</b>					
	15	180	---	DN 15 (opt. 25, 32)	0,5 - 5,0	0,8
	25	185	---	DN 25 (opt. 32, 40)	0,5 - 4,0	1,0
	<b>32502</b>					
	15	210	66	DN 15 (opt. 25, 32)	0,5 - 5,0	1,3
	25	215	81	DN 25 (opt. 32, 40)	0,5 - 4,0	2,0

## Safety relief valve, spring-loaded

### 32500/32501/32502

#### Performance data

Fluid: air			Fluid: steam		
32500/32501/32502					
pressure [bar-g]	throughput [Nm <sup>3</sup> /h]		pressure [bar-g]	throughput [kg/h]	
	DN 15	DN 25		DN 15	DN 25
1	32	89	1	24	68
2	49	135	2	37	102
3	65	182	3	49	135
4	82	228	4	61	169
5	99	---	---	---	---