

Pressure relief valve, spring-loaded

33502/33602

Description

Pressure relief valves are used in the beverage and food processing industries, as well as in the chemical-pharmaceutical industry.

Pressure relief valves:

- protection of pressurized systems against overpressure
- subject to the Pressure Equipment Directive 2014/68/EU
- may be used for the intensified purpose only
- fulfil the requirements of AD 2000/ A2 and DIN EN ISO 4126-1
- proportional opening characteristic for pressure regulation and maintenance of constant pressure respectively in pressure systems

CE 0062

Valve types

Type	Fluids	Lifting manual	Lifting pneumatic	Seals EPDM / FKM	Proximity switch	Heating cartridge
33502	F/G/D	X		X / ⊗	(⊗)	⊗
33602	F/G/D		X	X / ⊗	⊗	⊗

Liquids (F), Air/Gases (G), Steam (D)

⊗ optional



Valve data

Type	Safety relief valve
Type of functioning	Opens with pressure/closes with spring force
Order code	335xx/336xx

Product range

Materials	Stainless steel 1.4404
Seals	EPDM, optionally FKM/FPM (all FDA proof)
Surface	≤ 0.8 μm

Other parts

Materials	Stainless steel 1.4301, 1.4307
Seals	EPDM
Surface	Precision-turned, matte

Production / CIP

Applications	Free exit
Fluids (nontoxic)	Fluids/gases/steam (Group II, PED 2014/68/EU) Readily commercially-available CIP cleaning media with 2-4 % lye/acid
Performance data	Performance data within 10 % pressure increase
Operating pressure	PS min/max 0/10 bar-g
Temperature	TS min/max -20/160 °C
Control air pressure	5 – 7 bar, compressed air connection Ø 6/4 mm



Pressure relief valve, spring-loaded

33502/33602

Valve construction

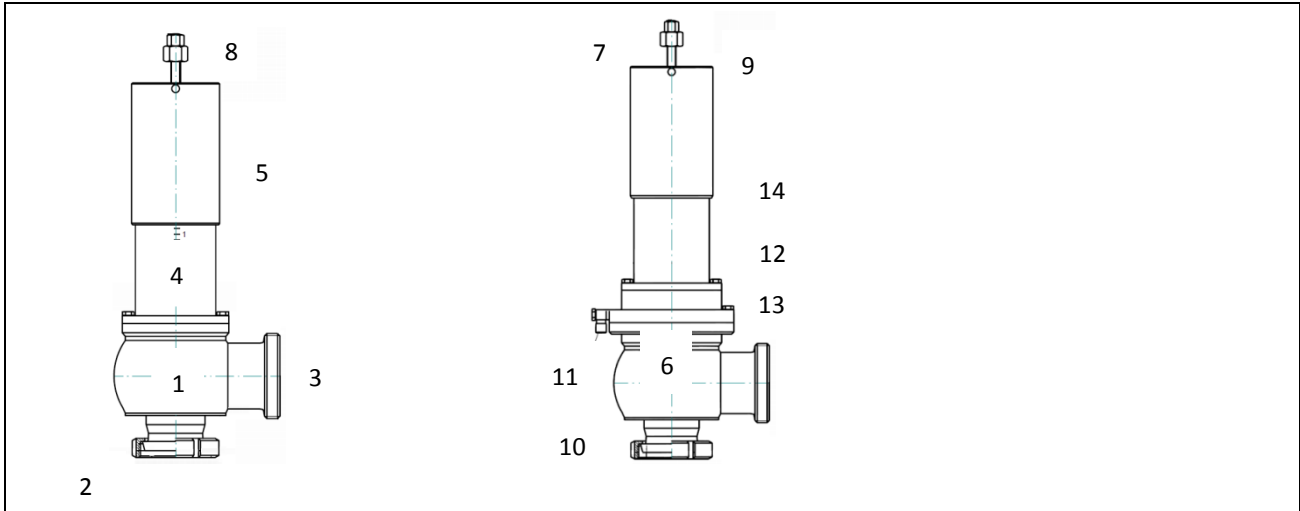

Fig. 1: Type 33502 und 33602

- | | | | |
|---|-------------------------------------|----|---------------------------|
| 1 | valve housing | 8 | lifting nut |
| 2 | valve inlet [E] – supply pipe | 9 | proximity switch |
| 3 | valve outlet [A] – discharge pipe | 10 | heating cartridge |
| 4 | upper valve body with scaling | 11 | compressed air connection |
| 5 | adjustment sleeve/ pressure setting | 12 | screws, upper body |
| 6 | pneumatic actuator | 13 | screws, actuator |
| 7 | valve rod | 14 | adjustment |

Pressure relief valve, spring-loaded

33502/33602

Dimensions

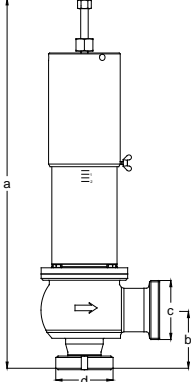
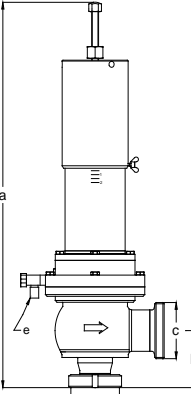
AH-SV-33502	DN [E]	DN [A]	a [mm]	b [mm]	c [Rd.Gew]	d (Gew)	weight [kg]
	50	65	617	88	95 x1/6"	78 x1/6"	14,2
	valve lift: max. 25 mm						
AH-SV-33602	DN [E]	DN [A]	a [mm]	b [mm]	c [Rd.Gew]	d (Gew)	weight [kg]
	50	65	672	88	95 x1/6"	78 x1/6"	22,0
	valve lift: max. 25 mm e: compressed air connection Ø: 6/4 mm						

Pressure relief valve, spring-loaded

33502/33602

Performance data

Fluid: water		Fluid: air		Fluid: steam	
33502/33602					
pressure	throughput [kg/h]	pressure	throughput [Nm ³ /h]	pressure	throughput [kg/h]
[bar-g]	DN 50	[bar-g]	DN 50	[bar-g]	DN 50
1	18.628	1	527	1	401
2	26.344	2	802	2	603
3	32.265	3	1.076	3	801
4	37.257	4	1.351	4	1.000
5	41.654	5	1.625	---	---
6	45.630	6	1.900	---	---
7	49.286	7	2.174	---	---
8	52.689	8	2.449	---	---
9	55.885	9	2.723	---	---
10	58.908	10	2.998	---	---