

GOOD,
BETTER,
BEST!

handtmann
Ideas for the future.



YOUR CHOICE!



DRY HOPPING

- Your Benefits:
- Safe operation on ground level (accident prevention)
 - No oxygen pickup during dry hopping due to preparation with CO₂
 - Dry Hop Tank including all pipes and fittings is fully CIP able



ENGINEERING/AUTOMATION

- Your Benefits:
- Handtmann expertise focuses on your process and plant parameters, resulting in excellent cost efficiency
 - The Handtmann automation team integrates your cold block into your existing system



YEAST- / WORT AERATION

- Your Benefits:
- Due to surround aeration - best mixing results of air/o₂ with yeast/wort will be achieved
 - 2 stage reduction and expansion phases do not require additional mixers
 - Best CIP performance!
 - No dead corners or complicated chambers



PIPING SYSTEM

- Your Benefits:
- Manual and semi-automatic pipe fence with swivel bends
 - Pipe concepts are designed individually for your requirements
 - Due to high degree of prefabrication, the installation time is reduced on-site



FILTRATION

- Your Benefits:
- Customized unit integration
 - Minimization of media consumption



YEAST MANAGEMENT

- Your Benefits:
- For propagation, storage and vitalization of yeast
 - Gentle yeast treatment
 - Cost savings by multifunctional equipment



TANK EQUIPMENT

- Your Benefits:
- Safety valves with ASME (UV) certification available
 - Easy to clean, prevention of microbiologically hazardous areas and contaminations
 - Design options for hot and cold cleaning



CIP SYSTEM

- Your Benefits:
- For maximum hygienic requirements
 - Exact chemical dosage controlled by flowmeters
 - Intelligent software for validated cleaning results



BEER STABILIZATION

- Your Benefits:
- Polyphenol reduction without PVPP
 - Adsorbermaterial can be used for years
 - Easy installation in any existing filter line
 - FDA (Food and Drug Administration) approved



FOAM TRAP

- Your Benefits:
- For "CO₂ free" and safe working area
 - Avoiding cross contamination during fermentation
- Power Blow:
- Reduces air consumption during the CO₂ blow out step during tank cleaning



STAND PIPE

- Your Benefits:
- To separate clear beer from yeast and hops
 - Recirculation from the bottom outlet via dosing skirts back to the stand pipe
 - Backwash cleaning of the standpipe is considered



BREWHOUSE

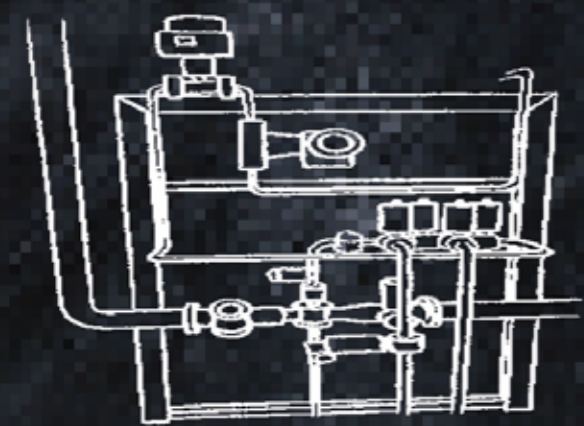

WORT AERATION

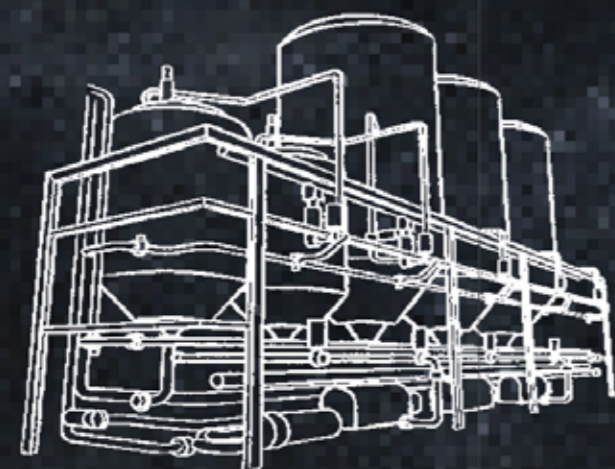

YEAST MANAGEMENT

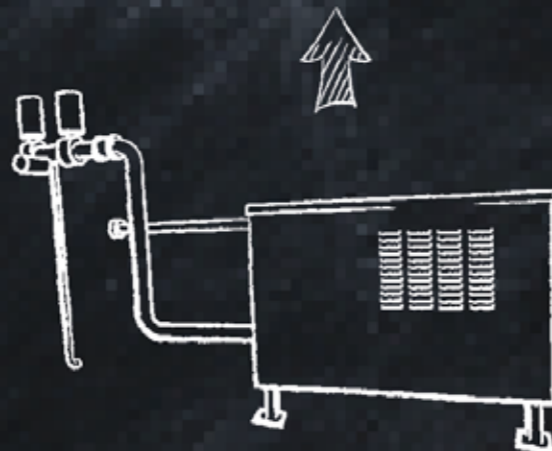

POWER BLOW

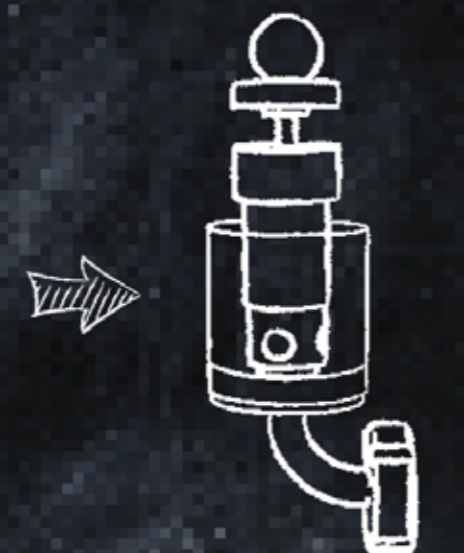

BUNGING DEVICE

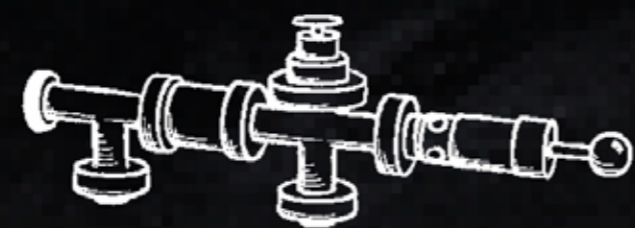

TANK TOP FITTINGS

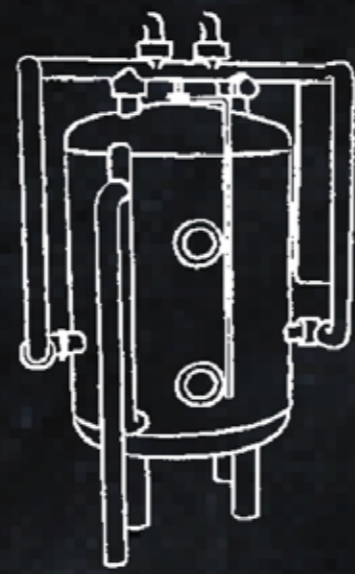

FOAM TRAP

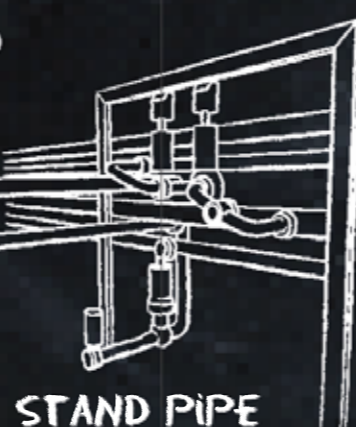

STAND PIPE



DRY HOPPING
HOP2TOP

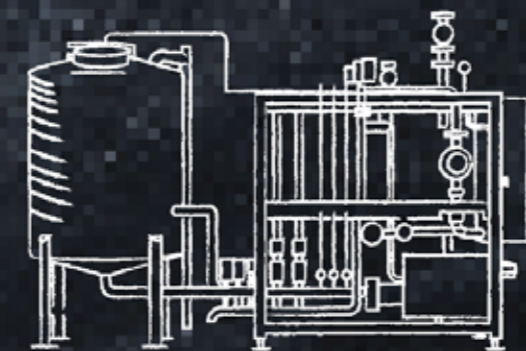

CIP-SYSTEM

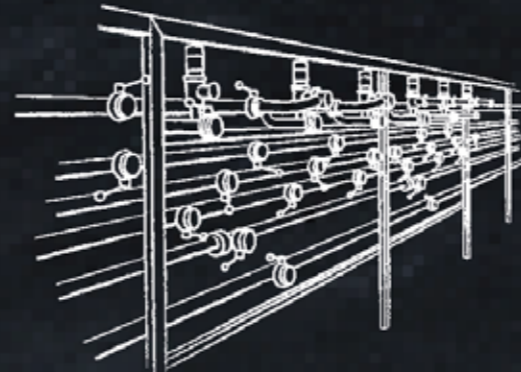

PIPING SYSTEM

THE BREWING PROCESS

WITH A LITTLE HELP FROM MY FRIENDS

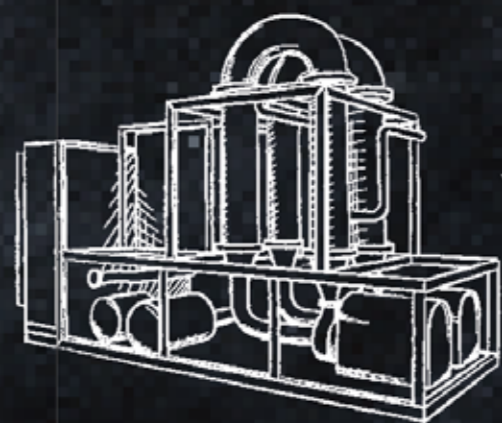

FILTRATION

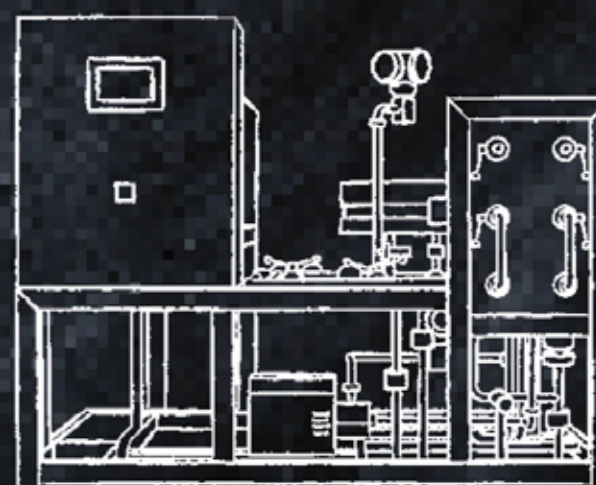

BEER STABILIZATION

BOTTLING



YOUR PARTNER
MADE IN GERMANY

Albert Handtmann Armaturenfabrik GmbH & Co. KG
Arthur-Handtmann-Str. 11
88400 Biberach/Riss
Deutschland
Tel.: +49 7351 342-0
Fax: +49 7351 342-4480
sales.fittings@handtmann.de
www.handtmann.de
www.facebook.com/HandtmannArmaturenfabrik

