

Vacuum valve (spring loaded)

12537

1	General	1
2	Safety Information	2
3	Delivery, Completeness, Storage	2
4	Installation, Operation, Maintenance	3
5	Additional Equipment	7

1 General

1.1 Manufacturer

Albert Handtmann Armaturenfabrik GmbH & Co. KG
Arthur-Handtmann-Str. 11; D-88400 Biberach
Tel.: +49(0) 73 51/3 42-0; Fax: +49(0) 73 51/3 42-44 80
E-Mail: sales.fittings@handtmann.de



1.2 Proper application

Vacuum valves are used in the food, beverage, pharmaceutical and chemical industries. They are suitable for the protection of tanks and other closed systems against negative pressure.

During installation, operation and maintenance please pay attention to the generally accepted safety regulations as well as to the operating instructions.

1.3 Misuse

Misuse is:

- Application in different operating conditions as intended for the specific type.
- Installation, operation and maintenance by unqualified staff.
- Any unauthorized modification of the valve or a valve component.
- On-observance of the operating instructions.

Any misuse will automatically lead to a loss of right to claim under guarantee as well as any liability.

1.4 Duties of operator

The operator has to make sure that:

- The valve/component is operated properly and only in functional condition.
- The legal requirements are kept during operation and maintenance.
- Only sufficiently qualified and authorized staff maintain the valve/component.
- The staff responsible for operation and maintenance know and obey the operating instructions and in particular the safety advice.
- The safety and warning signs remain on the valve/component and are always legible.

Vacuum valve (spring loaded)

12537

2 Safety Information

Notice and Safety

The following safety advice is an addition to existing national regulations and laws for accident prevention. Existing regulations and laws for accident prevention always have to be adhered to. Pay attention to the specific regulations and laws in your country.

The safety advice does not take into account:

- Coincidences and events that may occur during assembly, operation and maintenance.
- Local safety regulations in responsibility of the operator.

Basic safety advice

Requirements for a proper function of the valve/component:

- Proper transportation and storage
- Installation and setting into operation by authorized staff
- Operation according to these operating instructions – proper application
- Proper and regular maintenance



WARNING

Warning – general dangers!

To avoid danger for health and life the following safety instructions strictly have to be obeyed.

- Assembly and setting into operation only by qualified staff.
- Instruction and supervision by the operator.
- Keeping of technical and electrical data as specified in the operating instructions.
- Guarantee the electric safety of external devices.
- Keep legal regulations.

Non-observance may lead to the following dangers:

- Malfunction of the valve/component respectively of the plant.
- Danger for persons due to electrical, mechanical and chemical affects.
- Danger for the environment due to possible leakage of dangerous media.

3 Delivery, Completeness, Storage

- Check the data of the delivery note for factual correctness and the material for completeness. We regret that money cannot be refunded after purchase.
- Always check the material for transport damages. Possible damages have to be informed immediately.
- Store the material in a dry place and if possible in its original packaging.

Vacuum valve (spring loaded)

12537

4 Installation, Operation, Maintenance

Important notice!

- Valve/component suitable for vertical installation.
- Valve opens at a negative pressure of 3-5 mbar (30-50 mm WC).
Pressure compensation to ambient pressure by draw in air.
The valve will be closed by counter pressure of the weight.
- To avoid mistakes during assembly/disassembly, pay attention to the operating instructions respectively the type plate

4.1 Assembly instructions

Execution with heating device:

- The heating insets may only be connected according to attached scheme.
Pay attention to the connecting voltage!
- Do not remove the heating inset from the flange during function test (heating capacity). It may get damaged by overheating.

4.2 Operation

Type 12537

Construction with stainless steel valve DN 50 – DN 80

- Keep the valve clean.
- Lift the valve cone from time to time.
- Exchange the O-ring carefully.
- Avoid any damages at the valve seat.
- Protect vacuum valves from any force influence from outside.
- Any damage may affect the function.
- Admissible temperature: 90° / 125°C.

Vacuum valve (spring loaded)

12537

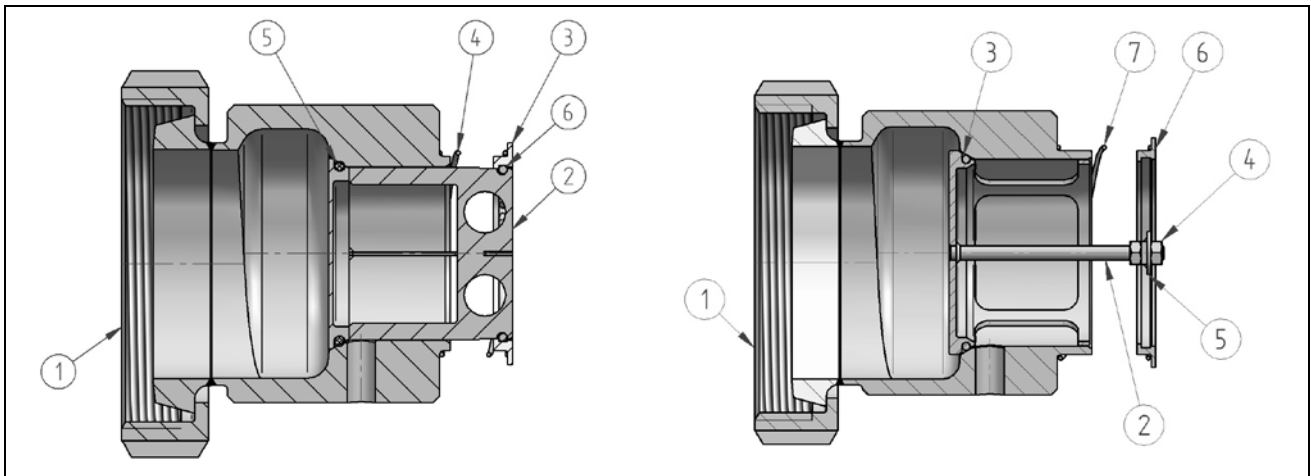

Fig. 1: Type 12537 DN 50

- 1 Valve housing
- 2 Valve cone
- 3 Pressure ring
- 4 Pressure spring
- 5 O-ring
- 6 Wire snap ring

DN 65

- 1 Valve housing
- 2 Valve cone
- 3 O-ring
- 4 Hex nut
- 5 Stop
- 6 Pressure ring
- 7 Pressure spring

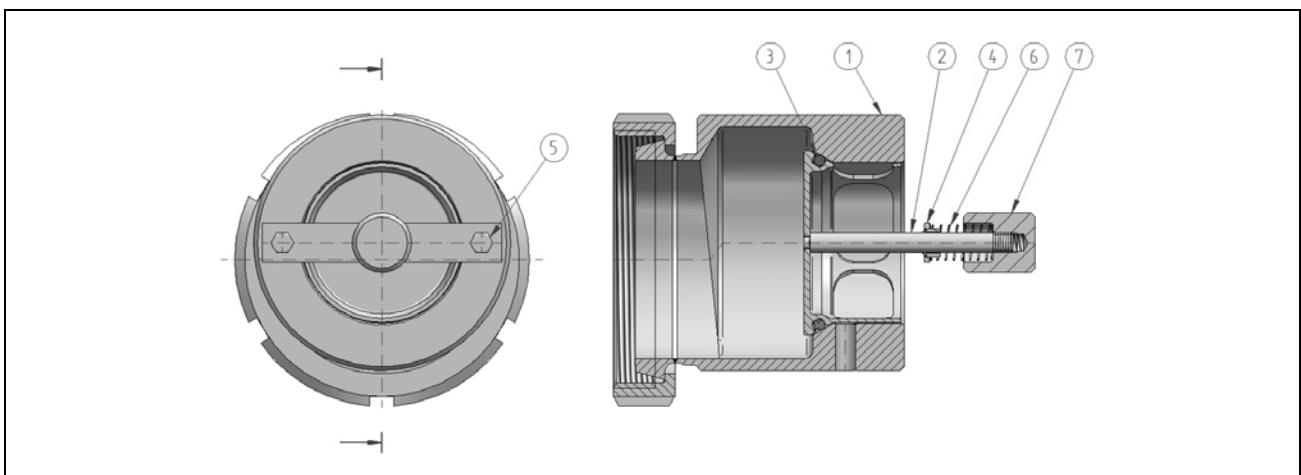

Fig. 2: Type 12537 DN 80

- 1 Valve housing
- 2 Valve cone
- 3 O-ring
- 4 Bridge
- 5 Hex nut
- 6 Pressure spring
- 7 Actuating handle

Vacuum valve (spring loaded)

12537

4.3 Maintenance

- The maintenance should be executed at regular intervals of min. every year. Depending on the operating conditions of the valves, these intervals may be shorter.
- During maintenance pay attention to the assembly and safety instructions.
- Any maintenance work may be carried out only in a depressurized system.

In case of spare parts orders please inform us the order No.

Gasket material EPDM

4.4 Seals

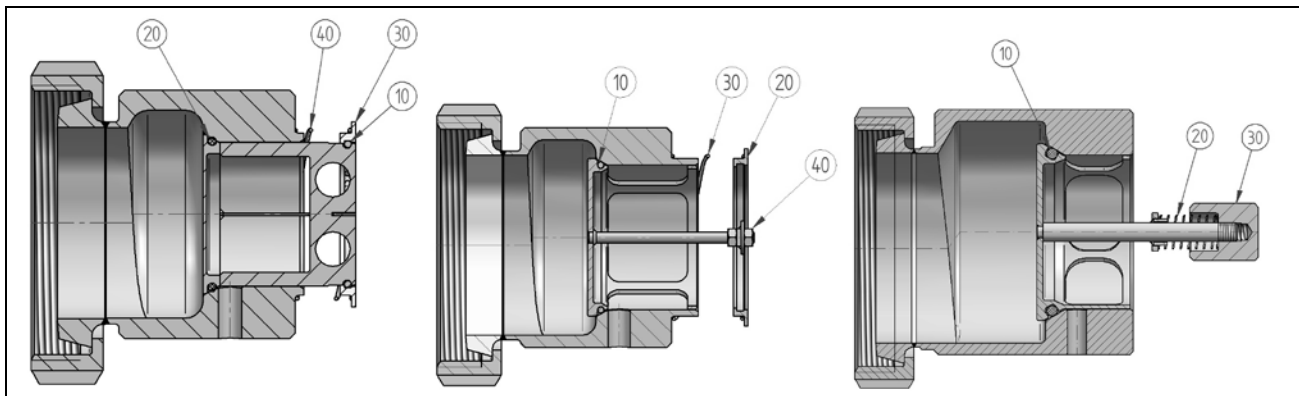

Fig. 3: DN 50 DN 65 DN 80

DN 50		DN 65		DN 80	
10	Wire snap ring	10	O-ring	10	O-ring
20	O-ring	20	Pressure ring	20	Pressure spring
30	Pressure ring	30	Pressure spring	30	Actuating handle
40	Pressure spring	40	Hex nut		

4.5 Spare parts

DN	12537
50	012537.00050LE
65	012537.00065LE
80	012537.00080LE

LE - EPDM

Vacuum valve (spring loaded)

12537

4.6 Identification of components

All vacuum valves (VV) must be provided with permanent identification of the component.

- Standard vacuum valves are provided with a setting value (4 mbar) specified by us (opening pressure range 3-5 mbar)

Explanation of the identification:

Numerical code	AH	VV	xxxxx	xxx	yyy	xx / xxxxx
	AH	VV	xxxxx	xxx	yyy	xx / xxxxx
Allocation	1	2	3	4	5	6

- 1 Manufacturer
- 2 Vacuum valve
- 3 Valve type
- 4 Nominal width / DN [mm]
- 5 Set negative pressure p [mbar]
- 6 Year of manufacture with manufacturing No

Vacuum valve (spring loaded)

12537

5 Additional Equipment

5.1 Heating insets

Heating insets							
DN	Connection-scheme №	Connection voltage Volt	Heating capacity Watt	Quantity	Rated power:		Part №
					Volt	Watt	
50-80	11 125E23	24	11.5	2*	24	23	105373

*Heating insets are integrated in the relevant heating elements

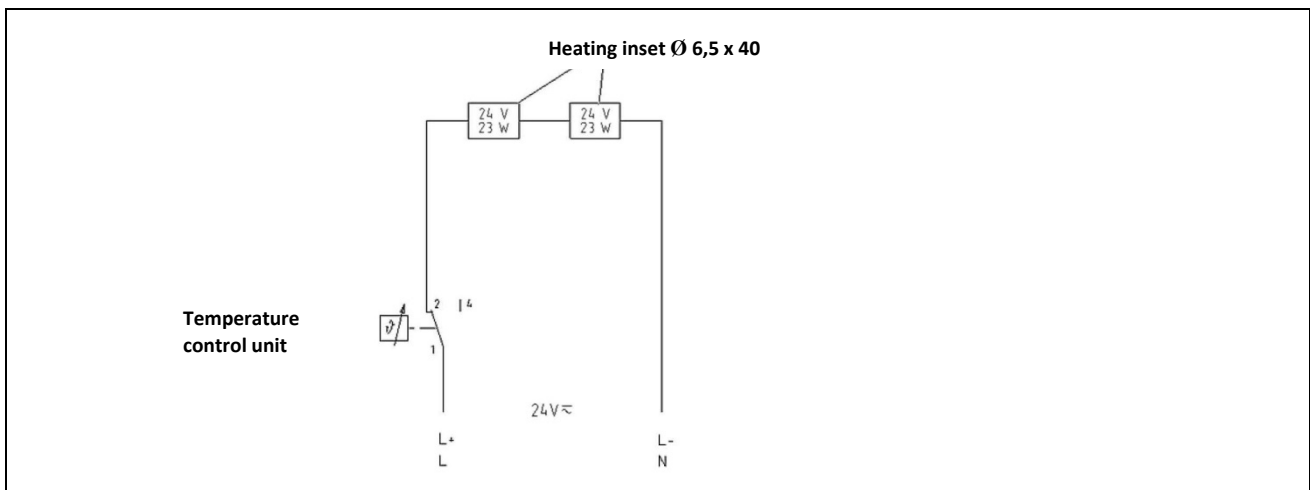

Fig. 4: E23, DN 50 – DN 80